



# XP-300 Series Sprinklers

## Installation & Service Instructions

### Introduction

The XP-300 Series Sprinkler is a multiple-stream gear-driven sprinkler ideal for residential and commercial applications. Sprinkler arc is determined by an Arc Disc™ located under the nozzle. Eleven arc discs are available to cover virtually any watering requirement. Three nozzle sizes are available to provide from 1.43–10.81 GPM flow and produce watering radii from 36'–43'. A fourth nozzle which provides 1.01–5.28 GPM flow and produces watering radii from 28'–31' is available only as a service replacement part.

To assure maximum performance from your XP-300 Shrub, Lawn or Hi-Pop sprinklers, please read the instructions completely prior to installation or servicing procedures.

### Specifications

#### Nozzle Performance

- Radius: 28'–43'
- Flow rate: 1.01–10.80 GPM
- Trajectory: 28°
- Maximum height of spray:
  - ▮ #05 Nozzle: 9' 3" @ 50 PSI
  - ▮ #07 Nozzle: 9' 1" @ 50 PSI
  - ▮ #09 Nozzle: 9' 1" @ 50 PSI
  - ▮ #10 Nozzle: 9' 6" @ 50 PSI

#### Shrub

- Recommended operating pressure: 35–60 PSI
- Maximum operating pressure: 75 PSI
- ½" and ¾" NPT female thread inlet
- Dimensions:
  - ▮ Body diameter: 1¾"
  - ▮ Height: 6½"

#### Lawn Pop-Up

- Recommended operating pressure: 35–60 PSI
- Maximum operating pressure: 75 PSI
- Pop-up: 3¾"
- Pop-up to nozzle: 3½"
- ½" and ¾" NPT female thread inlet
- Dimensions:
  - ▮ Body diameter: 2¾"
  - ▮ Cap diameter: 3"
  - ▮ Height: 6½"

#### Hi-Pop

- Recommended operating pressure: 35–60 PSI
- Maximum operating pressure: 75 PSI
- Pop-up: 12¾"
- Pop-up to nozzle: 12½"
- ¾" NPT female thread bottom and side inlet
- Side inlet – 7" from top of sprinkler to center of side inlet
- Dimensions:
  - ▮ Body diameter: 2¾"
  - ▮ Cap diameter: 3"
  - ▮ Height: 16½"

### Nozzle Performance Data

Nozzle	PSI	Rad.	Prec. Rates*		Gallons Per Minute										
			△	□	360°	270°	250°	225°	210°	195°	180°	165°	140°	115°	90°
<b>05</b> **	35	28'	.57	.50	4.04	3.03	2.81	2.53	2.36	2.19	2.02	1.85	1.57	1.29	1.01
	40	29'	.56	.48	4.23	3.24	3.00	2.70	2.52	2.34	2.16	1.98	1.68	1.38	1.08
	50	30'	.60	.52	4.83	3.62	3.35	3.02	2.82	2.62	2.42	2.21	1.88	1.54	1.21
	60	31'	.61	.53	5.29	3.97	3.67	3.31	3.09	2.87	2.65	2.42	2.06	1.69	1.32
<b>07</b>	35	36'	.49	.42	5.70	4.28	3.93	3.60	3.31	3.08	2.85	2.62	2.22	1.82	1.43
	40	38'	.47	.41	6.14	4.61	4.24	3.87	3.56	3.32	3.07	2.82	2.39	1.96	1.54
	50	40'	.48	.41	6.85	5.14	4.73	4.32	3.97	3.70	3.43	3.15	2.67	2.19	1.71
	60	41'	.49	.43	7.47	5.60	5.15	4.71	4.33	4.03	3.74	3.44	2.91	2.39	1.87
<b>09</b>	35	38'	.53	.46	6.94	5.21	4.79	4.37	4.03	3.75	3.47	3.19	2.71	2.22	1.74
	40	39'	.54	.47	7.43	5.57	5.13	4.68	4.31	4.01	3.72	3.42	2.90	2.38	1.86
	50	41'	.55	.48	8.38	6.29	5.78	5.28	4.86	4.53	4.19	3.85	3.27	2.68	2.10
	60	43'	.56	.48	9.26	6.95	6.39	5.83	5.37	5.00	4.63	4.26	3.61	2.96	2.32
<b>10</b>	35	37'	.65	.56	7.95	5.96	5.49	5.01	4.61	4.29	3.98	3.66	3.10	2.54	1.99
	40	39'	.63	.54	8.58	6.44	5.92	5.41	4.98	4.63	4.29	3.95	3.35	2.75	2.15
	50	41'	.65	.56	9.76	7.32	6.73	6.15	5.66	5.27	4.88	4.49	3.81	3.12	2.44
	60	42'	.68	.59	10.81	8.11	7.46	6.81	6.27	5.84	5.41	4.97	4.22	3.50	2.70

\* △ Precipitation rates are for triangular spacing, shown in inches per hour, calculated at 50% of diameter.

□ Precipitation rates are for square spacing, shown in inches per hour, calculated at 50% of diameter.

All performance specifications are based on the stated working pressure available at the base of the sprinkler head.

\*\* 05 Nozzle is available only as a service replacement part.

## Rubber Cover Kit – Lawn Pop-Up

Attach rubber cover (optional) to sprinkler cap, using Loctite Super Bonder® (or equivalent) adhesive as follows:

1. Assure bonding surfaces are dry and free of dirt, grease, and foreign substances.
2. Spread thin film of adhesive on underside of rubber cap cover and rubber nozzle cover.
3. Assemble immediately. Press retainer plug pins into two (2) holes in nozzle. See **Figure 1**.
4. Apply firm pressure until set (approximately 15 seconds).

## Installation Procedure

**NOTE:** Toro Funny Pipe® is recommended for ease of installation and accurate sprinkler positioning when installing the XP-300 Lawn and Hi-Pop sprinklers. Unlike a rigid connection, the flexible Funny Pipe link helps protect the PVC piping and fittings from breakage due to downward or lateral sprinkler movement. XP-300 Lawn and Hi-Pop sprinklers should be installed with top of cap level with finish grade (soil).

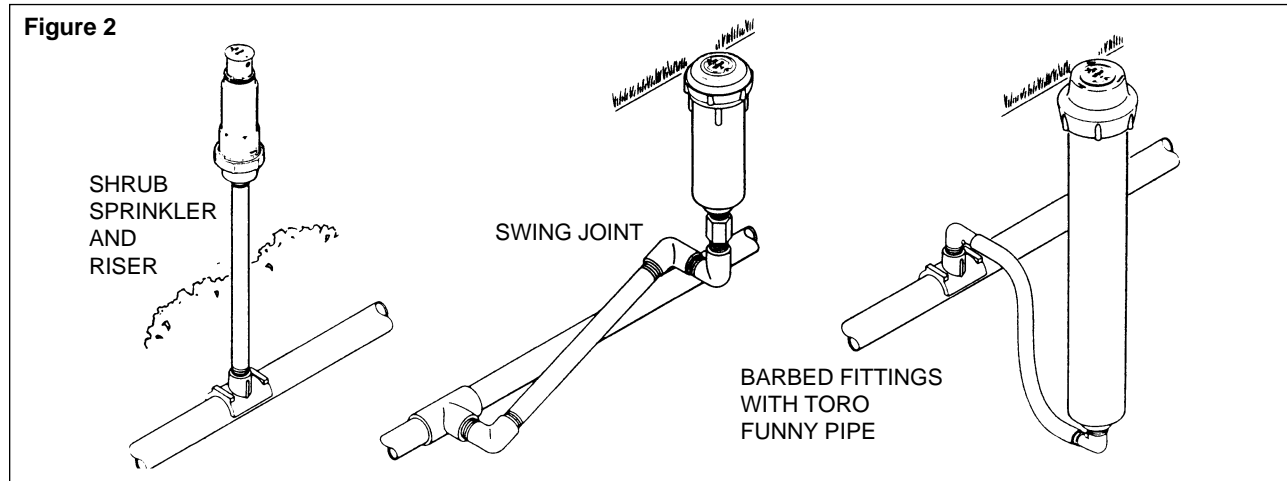
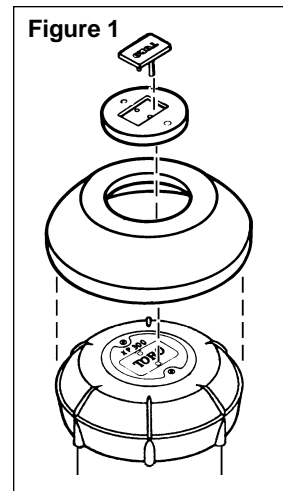

### CAUTION

Use only Teflon Tape™ to make threaded connections between polyethylene riser or barbed ell and sprinkler body. Deterioration of sprinkler body may occur if other sealing compounds are used.

## Shrub Sprinkler Installation

1. Flush all lines thoroughly prior to installing sprinkler on riser.
2. Grasp base of sprinkler by cap (not body) and screw securely onto teflon taped riser. Do not over-torque, handtight is sufficient.
3. To align part-circle sprinkler to coverage area, locate raised alignment dot on sprinkler shoulder (see **Figure 3**). Align dot with center of coverage area. If dot cannot be positioned correctly when sprinkler is tight, unscrew nozzle assembly and reposition Arc Disc to coverage area. (See **Figure 6**.)
4. Turn on water to system and refine part circle spray pattern.
5. Adjust spray radius if required (see **Figure 3**).

## Lawn and Hi-Pop Sprinkler Installation

1. Flush all lines thoroughly prior to installing sprinkler.
2. Grasp sprinkler by body (not cap) and screw securely onto teflon taped riser or barbed ell. Do not over-torque, handtight is sufficient.
3. To align part-circle sprinkler coverage area, locate raised dot on body and align with center of coverage area. If dot cannot be positioned correctly when sprinkler is tight, unscrew nozzle assembly and reposition Arc Disc to coverage area (see **Figure 9**). **NOTE:** Lawn Pop-Up has only one riser tab.
4. Backfill soil around sprinkler avoiding soil contact with nozzle assembly.
5. Turn on water to system and refine part circle spray pattern.
6. Adjust spray radius if required (see **Figure 3**).

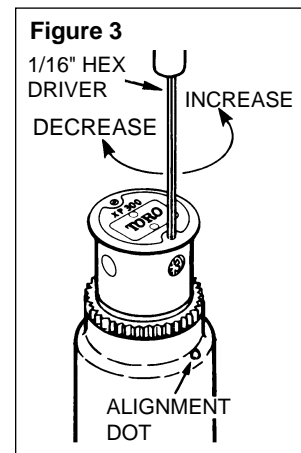

## Shrub Sprinkler Disassembly

1. Unscrew nozzle, lift out Arc Disc and Arc Disc seal.
2. Unscrew cap assembly from body and remove washer seal.
3. Remove basket screen from body and flush thoroughly to remove dirt and debris.
4. Remove variable stator from body. Clean ports if clogged.
5. Remove drive assembly from body by pressing gently on outer edge of drive assembly with flat blade screwdriver. (See Figure 4.)

### CAUTION

Do not apply pressure directly on center shaft of drive assembly. Push on outer edge of drive assembly housing. Excessive force applied directly to shaft may cause permanent damage to drive assembly and loss of sprinkler performance.

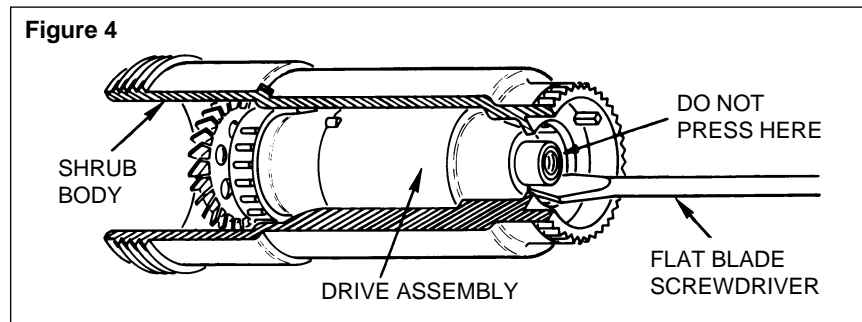

## Shrub Sprinkler Resassembly

1. Invert shrub body, install drive assembly (threaded end first), variable stator and basket screen.
2. Place washer seal into cap and screw cap onto shrub body.  
**NOTE:** Inspect Arc Disc seal for damage and replace if necessary.
3. Holding shrub body in upright position, install Arc Disk seal, tapered side up. (See Figure 5.)
4. Install Arc Disc, aligning center of part circle spray pattern with designated body tab. (See Figure 6.)
5. Screw nozzle assembly into drive assembly. (Do not overtighten.)

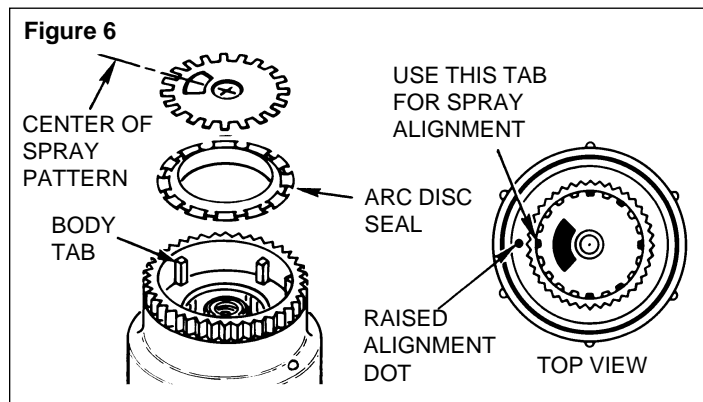
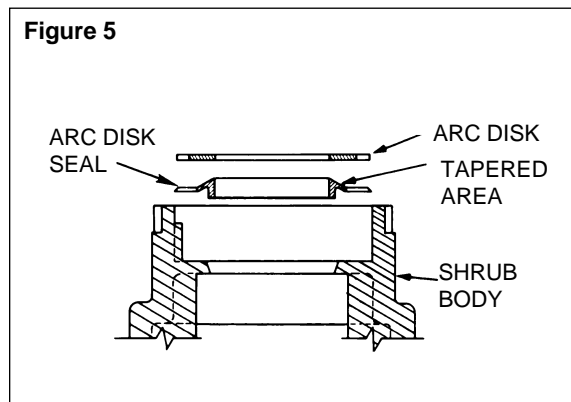

## Lawn and Hi-Pop Sprinkler Disassembly

1. Using 1/8" hex driver, loosen set screw on Locking Cap (Hi-Pop only).
2. Unscrew cap from body and remove cap, nozzle assembly and riser from body.
3. Remove basket screen from bottom of riser. Flush thoroughly to eliminate dirt and debris.
4. Push riser assembly through cap and grasp riser between cap and nozzle assembly firmly.
5. Unscrew and remove nozzle assembly.
6. Lift out Arc Disc and Arc Disc seal.
7. Slowly release riser assembly and remove cap, riser seal and return spring from riser.
8. Invert riser and pry-out variable stator assembly from Lawn Pop-up by inserting a knife edge between lip of stator and riser. Inspect stator and clean ports if clogged.
9. Remove drive assembly from riser by pressing gently on outer edge of drive assembly with flat blade screwdriver. (See Figure 7.) On Hi-Pop models, variable stator assembly will be pressed out with drive assembly.

### CAUTION

Do not apply pressure directly on center shaft of drive assembly. Push on outer edge of drive assembly housing. Excessive force applied directly to shaft may cause permanent damage to drive assembly and loss of sprinkler performance.

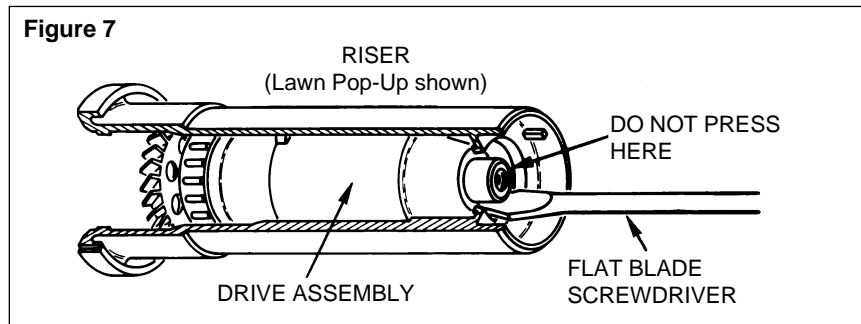

### Lawn and Hi-Pop Sprinkler Reassembly

1. Invert riser, install drive assembly (threaded end first) and variable stator assembly.

**NOTE:** To aid installation of variable stator assembly in Hi-Pop models, mark a piece of  $\frac{3}{4}$ " PVC pipe to  $10\frac{3}{4}$ " from one end. Place stator assembly over end of pipe and insert into riser until stop is felt or  $10\frac{3}{4}$ " mark is even with riser bottom.

2. Place return spring, riser seal and cap on riser, compressing spring with cap.

**NOTE:** Inspect Arc Disc seal for damage and replace if necessary.

3. Grasp riser firmly between cap and riser top and install Arc Disc seal, tapered side up (See Figure 8.)

4. Install Arc Disc, aligning center of part circle spray pattern with designated riser tab. (See Figure 9.)

**NOTE:** Lawn Pop-up has only one riser tab for alignment of Arc Disc.

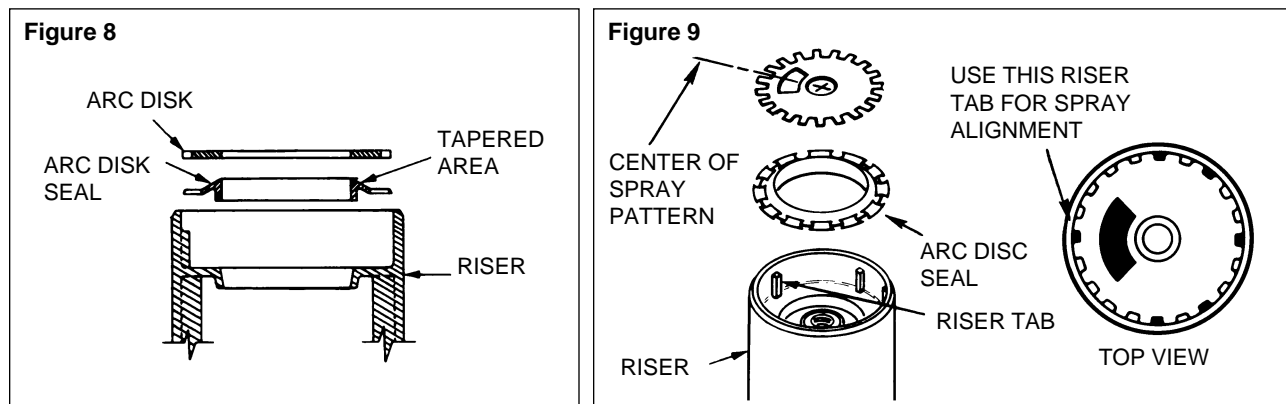

5. Screw nozzle assembly into drive assembly (do not overtighten) and slowly release cap.
6. Insert basket screen into riser bottom (Hi-pop). Press screen (Lawn Pop-up) onto riser bottom, aligning keys of screen with keyways of riser bottom.
7. Insert riser into body (see **NOTE** below).

**NOTE:** To properly align part-circle models, insert riser assembly into body aligning marked riser keyway with marked body key. These marks are located on bottom of riser (under screen on Lawn Pop-up) and raised dot on body exterior.
8. Screw cap onto body.
9. Tighten locking cap set screw (Hi-Pop only).

XP-300 Shrub		Item No.	Part No.	Nomenclature	Qty Per Assy.
	1	35-5460	Nozzle Assy., 5.0 GPM	1	
	1	XP300-02*	Nozzle Assy., 7.0 GPM	1	
	1	XP300-03*	Nozzle Assy., 9.0 GPM	1	
	1	XP300-04*	Nozzle Assy., 10.0 GPM	1	
	2	360-0223	Screw, Set, Half Dog Point	2	
	3	XP304-00*	Disc, Arc, 90°	1	
	3	XP305-00*	Disc, Arc, 115°	1	
	3	XP306-00*	Disc, Arc, 140°	1	
	3	XP307-00*	Disc, Arc, 165°	1	
	3	XP308-00*	Disc, Arc, 180°	1	
	3	XP309-00*	Disc, Arc, 195°	1	
3	XP310-00*	Disc, Arc, 210°	1		
3	XP311-00*	Disc, Arc, 225°	1		
3	XP312-00*	Disc, Arc, 250°	1		
3	XP313-00*	Disc, Arc, 270°	1		
3	XP314-00*	Disc, Arc, 360°	1		
4	35-2137	Seal	1		
5	35-2187	Body, Spray, Shrub	1		
6	35-8580	Drive Assy.	1		
7	35-2859	Stator Assy.	1		
8	9-5212	Screen, Basket	1		
9	9-5211	Seal	1		
10	89-6094	Threaded Insert, 3/4" - 1/2"	1		
11	89-8305	Base, Shrub	1		
		<b>Service Parts &amp; Assemblies</b>			
	9-5209	Base, Shrub (Pre-10/97)			
	9-5698	Insert, 1/2"			
	9-5699	Insert, 3/4"			
		* Order through Finished Goods Distribution System - Minneapolis			

XP-300 Lawn		Item No.	Part No.	Nomenclature	Qty Per Assy.
	1	-----	Plug, Retainer	0	
	2	-----	Cover, Rubber	0	
	3	35-5460	Nozzle Assy., 5.0 GPM	1	
	3	XP300-02*	Nozzle Assy., 7.0 GPM	1	
	3	XP300-03*	Nozzle Assy., 9.0 GPM	1	
	3	XP300-04*	Nozzle Assy., 10.0 GPM	1	
	4	360-0223	Screw, Set, Half Dog Point	2	
	5	XP304-00*	Disc, Arc, 90°	1	
	5	XP305-00*	Disc, Arc, 115°	1	
	5	XP306-00*	Disc, Arc, 140°	1	
	5	XP307-00*	Disc, Arc, 165°	1	
	5	XP308-00*	Disc, Arc, 180°	1	
	5	XP309-00*	Disc, Arc, 195°	1	
	5	XP310-00*	Disc, Arc, 210°	1	
5	XP311-00*	Disc, Arc, 225°	1		
5	XP312-00*	Disc, Arc, 250°	1		
5	XP313-00*	Disc, Arc, 270°	1		
5	XP314-00*	Disc, Arc, 360°	1		
6	35-2137	Seal	1		
7	9-4394	Cap	1		
8	9-4449	Seal, Riser	1		
9	9-2137	Spring, Return	1		
10	35-2138	Riser	1		
11	35-8580	Drive Assy.	1		
12	35-2858	Stator Assy.	1		
13	35-2136	Screen, Basket	1		
14	9-1661	Body	1		
		<b>Service Kits</b>			
	600-01	Kit, Rubber Cover (Includes Items 1 and 2)			
		* Order through Finished Goods Distribution System - Minneapolis			

# XP-300 High-Pop

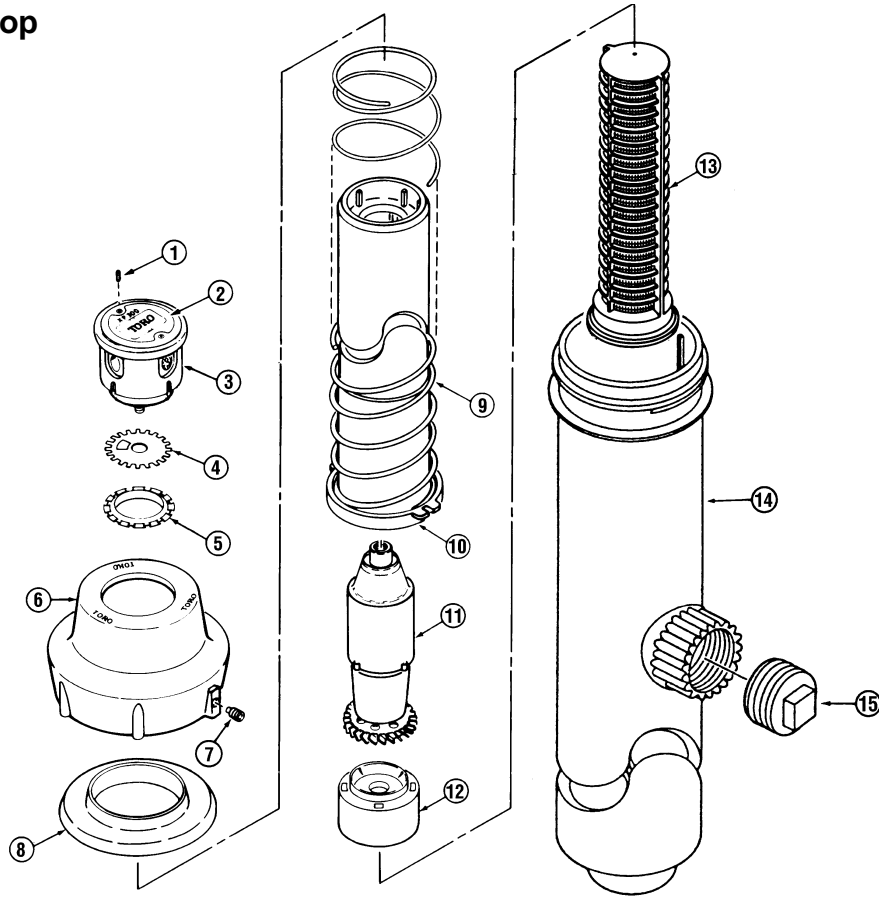

Item No.	Part No.	Nomenclature	Quantity Per Assy.
1	XP312-02*	Nozzle Assy., with sleeve, 7.0 (Includes Items 2 and 3)	1
1	XP312-03*	Nozzle Assy., with sleeve, 9.0 (Includes Items 2 and 3)	1
1	XP312-04*	Nozzle Assy., with sleeve, 10.0 (Includes Items 2 and 3)	1
2	360-0223	Screw, Set, Half Dog Point	2
3	35-2249	Sleeve, Nozzle	1
4	XP304-00*	Disc, Arc, 90°	1
4	XP304-00*	Disc, Arc, 90°	1
4	XP305-00*	Disc, Arc, 115°	1
4	XP306-00*	Disc, Arc, 140°	1
4	XP307-00*	Disc, Arc, 165°	1
4	XP308-00*	Disc, Arc, 180°	1
4	XP309-00*	Disc, Arc, 195°	1
4	XP310-00*	Disc, Arc, 210°	1
4	XP311-00*	Disc, Arc, 225°	1
4	XP312-00*	Disc, Arc, 250°	1
4	XP313-00*	Disc, Arc, 270°	1
4	XP314-00*	Disc, Arc, 360°	1
5	35-2137	Seal	1
6	35-4515	Cap, Locking (Includes Item 7)	1
7	360-0223	Screw, Set, Half Dog Point	1
8	35-3630	Seal, Riser	1
9	35-7579	Spring, Return	1
10	35-2247	Riser	1
11	35-8580	Drive Assy.	1
12	35-3822	Stator Assy.	1
13	9-4571	Screen, Basket	1
14	89-1960	Body	1
15	363-3187	Plug, 3/4 NPT Male	1

\* Order through Finished Goods Distribution System – Minneapolis