



Count on it.

FIELD PRO™ 6040
INFIELD GROOMER



**MAJOR LEAGUE RESULTS.
FOR YOUR HOME TEAM.**



FIELD PRO™ 6040 FEATURES

A Grade Above. From the Leader in Infield Maintenance.

Create ballfields that fans and players love with the Toro Field Pro 6040. This workhorse features efficient operation with the innovative MultiTool™, ergonomic operator comfort, and incredible versatility in attachment options. The dedicated platform produces a consistent, superior infield playing surface regardless of starting conditions. Precision engineering means precise results. With the Field Pro 6040, it's game on.



COMMERCIAL-GRADE CONSTRUCTION

The rugged chassis and commercial-grade components, produce major league playing surfaces for your home field.



LASER LEVEL CAPABILITY

An optional Laser Level Receiver System is able to be mounted to the Field Pro 6040 providing precise leveling and grade for optimal playing conditions.



MULTITOOL™

Combines the MultiTool Box Grader and MultiTool Adjustable Carrier to provide multiple options for varying field conditions.



EASY OPERATION

The Field Pro 6040 provides an ergonomic operator platform combined with intuitive controls and clear sight lines for all-day comfort.



MULTITOOL ADJUSTABLE CARRIER

Comes standard with Spring and Solid Tine Toolbars that are hydraulically-controlled for both depth and angle. Optional carbide, and weeder tines available.



QUICK ATTACH SYSTEM™ (QAS)

Add optional rear attachments in seconds – cocoa dragmat, nail drag, steel dragmat, tooth rake, spring rake, and much more.



MULTITOOL BOX GRADER

High-strength steel construction with changeable wear edge and adjustable grader angle. Can be fitted with an optional attachments such as a Field Edger, Box Blade Extensions, and Planer Blade kit.



FIELD PRO™ 6040 APPLICATIONS

Renovate.

Pre and post season infield renovation just got a whole lot easier. The Field Pro 6040 has a complete set of tools to get ball diamonds ready for the next season. Remove buildup and fill in low spots with the MultiTool Box Grader, made from high strength, durable steel and mounted on a rigid frame for reliable, consistent surface creation. Restore clean edge lines easily with the Field Edger, a hefty 21" (53 cm) diameter tool that blasts through the thickest turf encroachment. Loosen up tough compaction areas with the scarifying solid tines that can be easily set to a prescribed depth and angle right from the operator's position.



Maintain.

In-season maintenance, the key to safe, play-ready conditions on ball fields, is streamlined with the Field Pro 6040. Use the integrated Spring Tine Toolbar to efficiently yet lightly loosen compacted high wear areas. The rear drag can smooth out any ruts or uneven areas caused from extensive play or weather events. The Field Pro 6040's outstanding maneuverability and intuitive controls make quick work of returning fields back to play-ready conditions between games.



Perfect.

Bring a pro-level playing surface to any ball diamond with the Field Pro 6040's laser grading kit. Designed for precisely grading to a 1/8" (3 cm) accuracy, the laser receiver continually actuates the box blade to desired settings ensuring extremely consistent, smooth surface with proper slope profile for drainage and play. Combined with the rigid frame and commercial strength hydraulics, the laser leveling system enables any operator to achieve repeatable, all-star grading regardless of starting conditions.



FIELD PRO™ 6040 MULTI TOOL™ AND ATTACHMENTS

All the tools to make your job easier.

The MultiTool and attachment options take customized infield grooming to a whole new level. The system allows you to quickly change between tools, to keep operators productive all day long. Used in combination with rear drag attachments, the MultiTool will exceed your expectations, all in one pass.



MULTI TOOL™ (REQUIRED)

The Field Pro 6040 MultiTool is an innovative design that includes an integrated MultiTool Box Grader and an MultiTool Adjustable Carrier to quickly and accurately grade, groom and perfect your infields. When fitted with the optional laser grading system the Field Pro 6040 will easily grade your infield for optimal playing conditions.



MULTI TOOL™ ADJUSTABLE CARRIER

The MultiTool Adjustable Carrier allows for coarse or fine scarifying with standard Solid or Spring Tine Toolbars, allowing operator adjustments from field to field depending on conditions. Hydraulically-controlled depth and angle adjustment provide precise interaction, where needed, for desired results.



MULTI TOOL™ BOX GRADER

The integrated MultiTool Box Grader is nearly 6 feet (182 cm) wide for efficient and accurate grooming. Made from high-strength steel, the grader is built to last for years of dependable service. When fitted with the Box Blade Attachment Holder, the grader is able to incorporate several additional tools including a Field Edger, Box Blade Extension Kit, and Planer Blade Kit. Includes an abrasion resistant changeable wear edge.

MultiTool™ Accessories



LASER LEVEL INSTALLATION KIT

Allows an optional Laser Level Receiver System to integrate to a Field Pro 6040.



BOX BLADE ATTACHMENT HOLDER

Receiver for the Field Edger, Planer Blade Kit, and Box Blade Extension Kit.



BOX BLADE EXTENSION KIT

Left and right hand extensions increase MultiTool Box Grader grading width to nearly 8 feet (244 cm) wide.



FIELD EDGER

Used for edging outfields for a clean edge, its 21" (53.3 cm) disc is built for commercial applications. Can be mounted on either the left or right side of the machine.

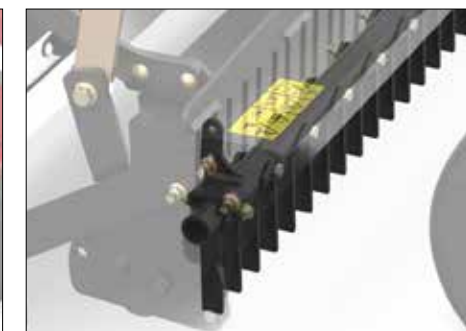

SOLID TINE TOOLBAR

Great for loosening compacted infields. Comes standard with the MultiTool.



SPRING TINE TOOLBAR

Use for light to moderate scarifying and daily maintenance of infields. Comes standard with the MultiTool.



PLANER BLADE KIT

Set of three (3) planer blades to mount to the Box Blade Attachment Holder. Used to aggressively cut weeds under the grade.



WEEDER TINE TOOLBAR KIT

Ideal for removing weeds and grass from infields.



CARBIDE TINE TOOLBAR KIT

Great for loosening compacted infields with long-lasting carbide tips.

FIELD PRO™ 6040 REAR ATTACHMENTS

The Quick Attach System™ (QAS) allows you to change attachments in seconds, without tools.

Match the machine to the environment to get your fields back into playing condition. QAS allows you to do more with less, and get the job done faster.



QAS Nail Drag & Accessories



QAS NAIL DRAG
Use to scarify, loosen, or weed before smoothing. Easily adjust nail pattern and depth.



QAS NAIL DRAG (SHOWN WITH OPTIONAL FLEX GROOMER KIT)
Offers complete grooming in one pass.

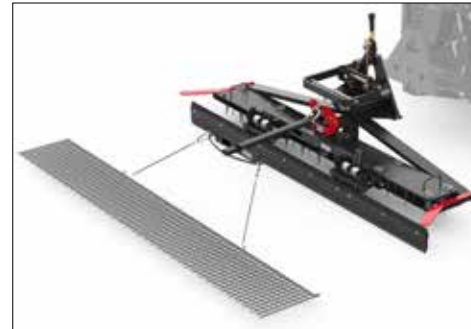

QAS NAIL DRAG (SHOWN WITH OPTIONAL FLEX GROOMER AND AUTOMAT DRAG MAT)
Automatically engages the infield skin as the Nail Drag is lowered.

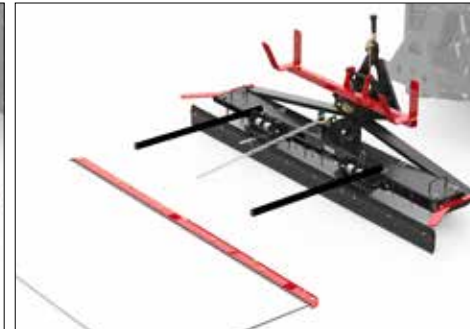

QAS NAIL DRAG (SHOWN WITH OPTIONAL FLEX GROOMER AND MANUAL DRAG MAT)
Smooths and evens scarified surfaces.

QAS Tooth Rake & Accessories



QAS TOOTH RAKE
Lightly scarify, pack, smooth, and groom in wet or dry conditions.

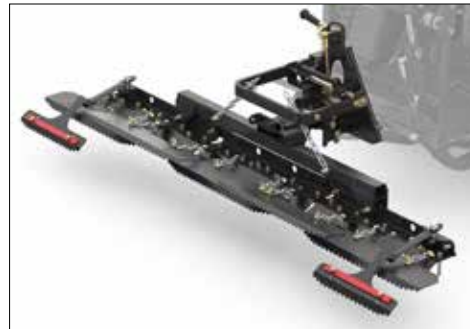

QAS TOOTH RAKE (SHOWN WITH OPTIONAL PIVOT TROWEL KIT)
Provides full grooming around corners and near bases.

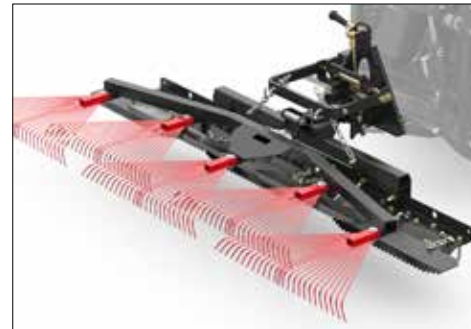

QAS TOOTH RAKE (SHOWN WITH OPTIONAL SPRING RAKE)
Leaf rake assembly is great for collecting debris in groomed areas.



QAS TOOTH RAKE (SHOWN WITH OPTIONAL BROOM KIT)
Attaches behind the Tooth Rake providing a smoother finish.

QAS Finish Grader & Accessories

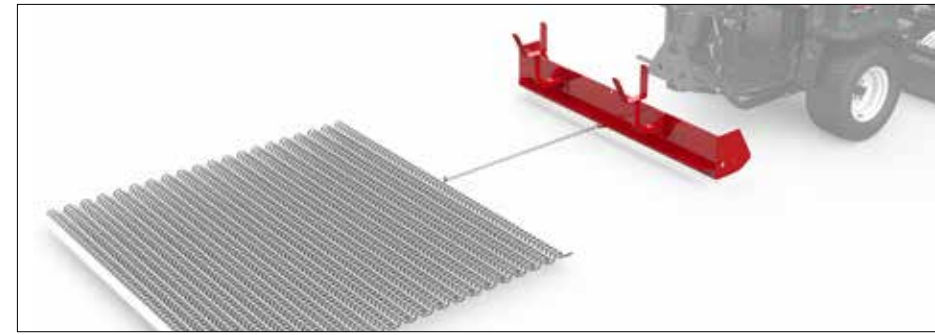

QAS FINISH GRADER (SHOWN WITH OPTIONAL DRAG MAT KIT)
Allows a rear mounted grader option. Optional Weeder Tines or Carbide Tines for increased versatility.

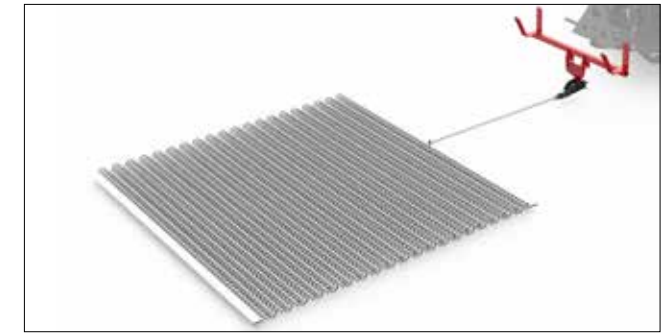

BASIC DRAG MAT SYSTEM
Used to even out rutted and high-wear areas between games. Attaches directly to the optional QAS A-Frame.



QAS A-FRAME
Used to pull the optional Basic Drag Mat or attach customer fabricated drag attachments.

QAS Drag Mat Carrier & Accessories



STEEL DRAG MAT*
For the same finish in more rugged surfaces compared to a Basic Drag Mat.



COCOA DRAG MAT*
Produces a premium finish in dry and level surfaces. Less aggressive and does not displace much infield top dressing.



QAS FLEX TOOTH RAKE
Rubber groomer design prevents furrows for superior after-groom appearance.

Stand Alone Accessories

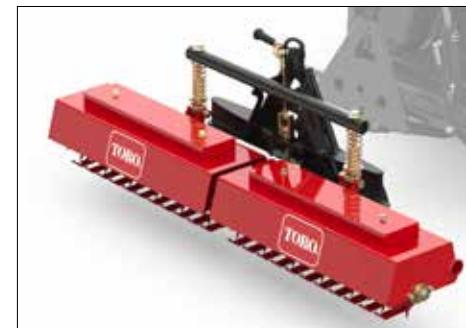

QAS SPIKER
Spikes infield or outfield grass to help increase oxygen exchange in the grass canopy.

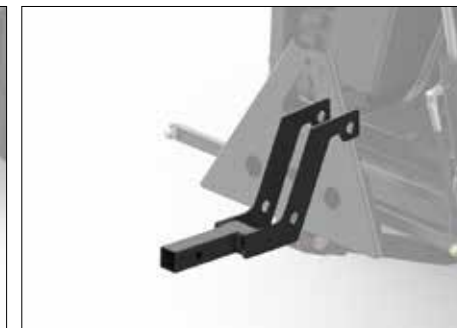

DRAW BAR HITCH KIT
Allows connection to small third-party draw-bar style attachments.



REAR STORAGE & TOOL HOLDER KIT
Convenient storage for supplies and holders for a rake, shovel or other tools.

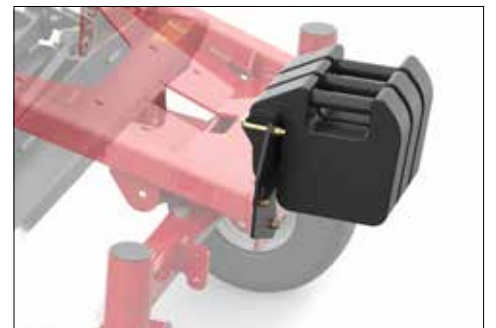

FRONT WEIGHT MOUNT KIT
Allows three suitcase weights to be added for additional grading down pressure.

Visit toro.com or call your local distributor for a full list of available accessories and attachments.

*Requires the Drag Mat Carrier System

SAND PRO™ 3040/5040

Infield grooming and a whole lot more.

Complementing the Field Pro 6040 stand-on machine, the Sand Pro 3040 and 5040 are the ultimate riding groomers. Representing over 50 years of infield grooming and maintenance, these efficient task masters offer a multitude of solutions to match the varying needs each field may present. With its tool-free Quick Attachment System (QAS), change-outs of dozens of rear attachments are greatly simplified, most of which can be shared with the Field Pro. And the 5040's optional front, steerable QAS provides added flexibility and surgical precision. Together with the mid-mount tool bar options, the Sand Pro keeps infields in tournament-ready condition every day.



Sand Pro® 3040



Sand Pro® 5040

FRONT ATTACHMENTS*

- Hydraulic Flex Blade
- Manual Blade
- Bunker Pump
- Lip Broom
- Nordic Plow

MID ATTACHMENTS

- Weeder Tine Toolbar
- Spring Tine Toolbar
- Solid Tine Toolbar
- Carbide Tine Toolbar
- Sports Field Edger*

REAR ATTACHMENTS

- Flex Tooth Rake
- Manual Drag Mat
- Cocoa Drag Mat
- Steel Drag Mat
- Bunker Pump*
- Segmented Grooming Broom
- Spiker
- Finish Grader
- Lip Broom
- Spring Rake
- Nail Drag
- Tooth Rake
- Flex Groomer
- AutoMat Drag Mat
- Rahn Groomer**
- Basic Drag Mat

SPECIFICATIONS*

	FIELD PRO™ 6040	SAND PRO® 3040	SAND PRO® 5040
ENGINE	Kohler® Command PRO® 4-cycle OHV commercial gas engine. 25hp (18.6 kW) at 3600 RPM (SAE J1940). 44.0 cu. in. (725 cc). Oil Capacity: 2.0 quarts (1.9 liter).	Vanguard®, V-twin cylinder, 4-cycle, OHV, air-cooled, gas engine with cast iron sleeves. 16 hp (11.9 kW) at 3600 rpm. Displacement: 29.3 cu. in. (480 cc). Oil capacity: 1.75 quart (1.8 liter).	Vanguard®, V-twin cylinder, 4-cycle, OHV, air-cooled, gas engine with cast iron sleeves. 18 hp (13.4 kW) at 3600 rpm. Displacement: 34.8 cu. in. (570 cc). Oil capacity: 1.75 quart (1.8 liter).
AIR CLEANER SYSTEM	Premium air filtration system.	Remote-mounted 3-phase Donaldson® air cleaner.	
FUEL CAPACITY	8.0 gallon (36.3 liter) unleaded gasoline.	5.0 gallon (18.9 liter) of unleaded gasoline.	
TRACTION DRIVE	Independent commercial grade high-torque wheel motors.	Direct driven hydrostatic variable displacement piston pump to 3 hydraulic motors for 3WD. Large, front mounted hydraulic cooler and fan. Foot pedal control, forward/reverse. Patented Series/Parallel hydraulic traction system keeps three wheels working together, virtually eliminates spin-outs.	
GROUND SPEED	Infinitely variable 0-10 mph (0-16 km/h) forward; 0-5.0 mph (0-8.0 km/h) reverse.	Infinitely variable 0-10 mph (16 km/h) forward; 4.3 mph (6.9 km/h) reverse.	
HYDRAULIC OIL	7.5 gallon (28.4 liter) system capacity. Polyethylene reservoir to reduce corrosion. 5 (nominal) micron replaceable cartridge.	5.0 gallon (18.9 liter) system capacity. Polyethylene reservoir to reduce corrosion. 10 (nominal) micron replaceable cartridge.	
MULTITOOL™	Model 08854, sold separately – mid-mounted MultiTool includes an integrated 68" (172 cm) MultiTool Box Grader and MultiTool Adjustable Carrier with Spring Tine and Solid Tine Toolbars.	N/A	
TIRES/WHEELS	Rear: 24 x12.00-12, Front: 15 x 6.00-6 commercial caster wheels.	Three 22 x 11.00-8 pneumatic tubeless tires on demountable, interchangeable wheels. Tire pressure: 8-10 psi (55.2-69 kPa).	
CONTROLS/GAUGES	Hand operated choke, throttle, and hydraulic controls for raising/lowering and actuating the MultiTool Adjustable Carrier. QAS Rear hydraulic lift and lower controls. Gauges: fuel, hour meter.	Hand operated choke, throttle, and hydraulic control for raising/lowering with float. Foot pedal controls traction forward/reverse speed. Rear hydraulic lift and lower controls. Gauges: hour meter.	Hand operated choke, throttle, and hydraulic control for raising/lowering with float. Foot pedal controls traction forward/reverse speed. Front and rear hydraulic lift and lower controls. Gauges: hour meter.
DIMENSIONS	Width: 67.8" (172 cm), Length: 103.8" (264 cm), Height: 50.7" (134 cm), Wheelbase: 59.6" (151 cm)	Width: 58" (147 cm), Length: 67.5" (171.5 cm), Height: 45.25" (114.9 cm), Wheelbase: 42.75" (108 cm)	
GROUND CLEARANCE	7.3" (18.4 cm)	6.0" (15.2 cm)	
WEIGHT	Net weight (less fluids): 1,620 lbs. (735 kg) with MultiTool installed.	Net weight (less fluids): 930 lbs. (421.8 kg)	
WARRANTY	Two-year limited warranty. Refer to the Operator's Manual for further details.	Two-year limited warranty. Refer to the Operator's Manual for further details. Briggs & Stratton® provides a two-year commercial engine warranty and a lifetime Magnetron® warranty.	

*Specifications and design subject to change without notice. Products depicted in this literature are for demonstration purposes only. Actual products offered for sale may vary in use, design, required attachments and safety features. See distributor for details on all warranties.

**Not compatible with the Field Pro 6040

**Available from Rahn Industries at RahnIndustries.com 800-298-1707.

Visit toro.com or call your local distributor for a full list of available accessories and attachments.



Count on it.

LEARN MORE

CONTACT US AT: **800-803-8676**
OR VISIT US AT: **toro.com**

©2022 The Toro Company. Bloomington, MN 55420 All rights reserved.
All other trademarks are property of their respective owners. Printed in the USA.

Part Number 22-060-T

Products depicted in this literature are for demonstration purposes only. Actual products offered for sale may vary in use, design, required attachments and safety features. We reserve the right to improve our products and make changes in specifications, design and standard equipment without notice and without incurring obligation. See your distributor for details on all our warranties.

FOLLOW US!



facebook.com/toro
twitter.com/TheToroCompany
twitter.com/ToroGolf
twitter.com/ToroGrounds
youtube.com/toro
linkedin.com/company/the-toro-company

